

A VERSATILE, COMPACT X-RAY INSPECTION SYSTEM WITH OUTSTANDING IMAGE QUALITY

MEETS ALL EUROPEAN
COMMISSION AVIATION
SCREENING REQUIREMENTS

SINERGY™ LOW DENSITY
IMAGE ENHANCEMENT

COMPACT DESIGN, PORTABLE

EXPLOSIVES AND NARCOTICS
DETECTION

STANDARD FEATURES

- Multi Energy Imaging (4 Color)
- View Previous/Next Bag
- Image Archive
- Configurable Image Processing Keys
- Baggage Counter
- Date / Time Display
- Search Indicator
- UPS (Uninterrupted Power Supply)
- Flat Panel Monitor
- Multi Language Support

STANDARD IMAGE PROCESSING FUNCTIONS

- Crystal Clear™
- SINERGY™
- Black and White
- Organic / Inorganic Stripping
- Inverse Video
- High Penetration
- Low Penetration
- Pseudo Color
- Variable Edge Enhancement
- Variable Color Stripping
- Variable Gamma
- Variable Density
- Dynamic Continuous Zoom & Panning
- Fixed Zoom (64x)

sales@rapiscansystems.com
www.rapiscansystems.com



TUNNEL OPENING (W X H):
540 X 360 MM (21.3 X 14.2 IN)

THE NEW RAPISCAN 618XR hp IS A HIGH PERFORMANCE COMPACT AND VERSATILE 540 MM BY 360 MM TUNNEL X-RAY SYSTEM WITH EXCEPTIONAL IMAGE QUALITY AND EXCELLENT THREAT DETECTION ALERT CAPABILITIES.

The Rapiscan 618XR hp complies with European Commission aviation screening requirements.

DETECTION OF EXPLOSIVES AND NARCOTICS ALERT

Target™ and NARCScan™ are designed to assist operators in the detection of a range of explosives and narcotics respectively in real time during the scanning process by marking a potential threat on the X-ray image. Rapiscan detection algorithms are based on regulatory material analysis techniques.

GOVERNMENT REGULATORY COMPLIANCE

Rapiscan 618XR hp performance is in full compliance with the mandatory regulations (EC) No. 300/2008, (EU) No. 185/2010 and Commissions Decision C(2010)774 for aviation security in the European Union.

EASE OF USE PROVIDING HIGHEST THROUGHPUT

With over 14 image processing tools and detection alert algorithms functions, the feature-rich software allows the operator to more easily and accurately search for contraband.

SINERGY™

Rapiscan's latest proprietary image enhancement tool, utilizes the new innovative Dual-Mode X-ray imaging Technique (DMxI) to emphasize the detail in specific regions of images by enhancing the visibility of thin metal therefore increasing operator recognition of potential threats in cluttered images.



HIGH PERFORMANCE RAPISCAN 618XR hp

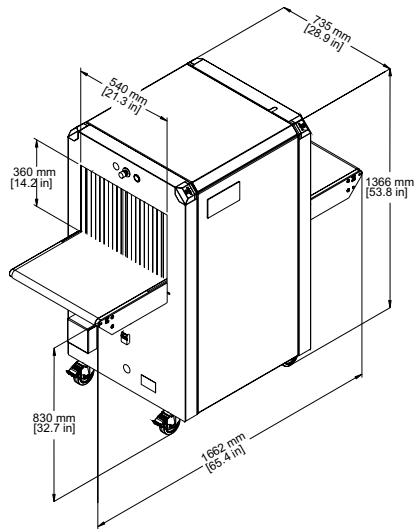

PHYSICAL SPECIFICATIONS

Dimensions:	Length: 1,662 mm (65.4 in.) Width: 735 mm (28.9 in.) Height: 1,366 mm (53.8 in.)
Tunnel Size:	540 mm (W) x 360 mm (H) (21.3 x 14.2 in.)
Conveyor Speed:	0.20 m/sec (39.4 ft./min)
Conveyor Load (Max):	165 Kg (364 lbs) evenly distributed
Conveyor Height (Approx.):	830 mm (32.7 in.)
Weight (Approx.):	440 kg (970 lbs.)
System Power:	100/110/120/200/208/220/230/240VAC ±10%

X-RAY GENERATOR AND IMAGE PERFORMANCE¹

Steel Penetration:	33 mm typical, 31 mm standard
Wire Resolution:	40 AWG typical, 38 AWG standard
Spatial Resolution:	0.8mm vertical/ 0.8mm horizontal
Cooling:	Sealed oil bath with forced air
Anode Voltage:	140kV
Orientation:	Diagonally Upward

OPERATING ENVIRONMENT

Storage Temperature:	-20°C to 50°C
Operating Temperature:	0°C to 40°C
Relative Humidity:	5 to 95% non-condensing

PROTECTION CLASS

System:	IP20
Operator Control Panel:	IP43 ²

GOVERNMENT REGULATORY

- Regulation (EC) No. 300/2008 Compliant
- Regulation (EU) No. 185/2010 Compliant
- EU Commissions Decision C(2010)774 Compliant

HEALTH & SAFETY

Rapiscan Systems' cabinet X-ray products comply with all applicable U.S. FDA and equivalent international regulatory agency requirements, contained in the cabinet X-ray radiation safety performance standard [21 CFR 1020.40] and the general performance standard [21 CFR Part 1010] as well as IEC standard 61010-2-091.

Rapiscan baggage and parcel inspection systems radiation emission leakages are well below the required regulatory limits with less than 1 µSv/hr at 10 cm from all surfaces of cabinet X-ray.

AMERICAS, CARIBBEAN

2805 Columbia Street
Torrance,
California
90503

UNITED STATES of AMERICA

Tel: +1 310-978-1457
Fax: +1 310-349-2491

EUROPE, MIDDLE EAST, AFRICA

X-Ray House
Bonehurst Road
Salfords
Surrey RH1 5GG

UNITED KINGDOM

Tel: +44 (0) 870-7774301
Fax: +44 (0) 870-7774302

ASIA

240 Macpherson Road
#07-01 Pines Industrial Building
Singapore
348574

SINGAPORE

Tel: +65-6846-3511
Fax: +65-6743-9915

Rapiscan[®] systems

An OSI Systems Company

SOFTWARE

- OS600
- 64-bit Operating System

OPTIONS AND ACCESSORIES

- Explosives Detection Alert (Target™)
- Narcotics Detection Alert (NARCScan™)
- Density Threshold Alert (DTA)
- Threat Image Projection (TIP)
- Threat Image Projection Network (TIPNet)
- Remote Image Archive Review (NETView™)
- Multi-System Network Display Station (NDS)
- Automatic Image Archiving
- Enhanced Image Archiving
- Operator Training Program (OTP)
- Manual Scan
- Operator Pedestal
- Foot Mat
- Optical Operator Presence Sensor
- SmartCard Login
- Power Conditioner
- Conveyor Accessories
- Remote Workstation
- Universal Printer Support
- Operator Control Panel
- Bracket Mount - Dual Monitor Kit
- Extended UPS

¹ Stated performance as measured by Rapiscan Imaging Validation Test Kit.

² With optional replaceable cover.

With continual development of our products Rapiscan Systems reserves the right to amend specifications without notice. Product pictures are for general reference. Please note that due to US laws and regulations, not all Rapiscan products are available for sale in all countries without restriction. Please contact your Rapiscan Systems sales representative for more information.

Part Number | 618XRH140



Rapiscan Systems is ISO 9001:2008 and ISO 14001:2004 + Cor. 1:2009 Certified

sales@rapiscansystems.com
www.rapiscansystems.com