

## EASY LOADING CONVEYOR AND LARGE TUNNEL FOR X-RAY SCREENING OF LARGE BAGGAGE AND PARCELS.

LARGE PARCEL AND SMALL CARGO SCREENING

EASY LOADING CONVEYOR

MEETS GLOBAL REGULATORY REQUIREMENTS

COST EFFECTIVE

### STANDARD FEATURES

- Multi Energy Imaging (4 Color)
- View Previous/Next Bag
- Image Archive
- Configurable Image Processing Keys
- Baggage Counter
- Date / Time Display
- Search Indicator
- UPS (Uninterrupted Power Supply)
- Multi Language Support
- Flat Panel Monitor

### STANDARD IMAGE PROCESSING FUNCTIONS

- Crystal Clear™
- Black and White
- Organic / Inorganic Stripping
- Inverse Video
- High Penetration
- Pseudo Color
- Low Penetration
- Variable Edge Enhancement
- Variable Color Stripping
- Variable Gamma
- Variable Density
- Dynamic Continuous Zoom & Panning
- Fixed Zoom (64x)

[sales@rapiscansystems.com](mailto:sales@rapiscansystems.com)  
[www.rapiscansystems.com](http://www.rapiscansystems.com)



Tunnel Opening (width x height):  
1,000 x 1,000 mm (39.4 x 39.4 in)

WITH A HIGH TUNNEL OPENING AND A LOW CONVEYOR, THE RAPISCAN 628XR IS DESIGNED FOR CUSTOMERS THAT NEED EASY LOADING AND UNLOADING OF SMALL CARGO AS WELL AS BAGGAGE AND LARGE PARCELS DURING THE SCREENING PROCESS FOR AVIATION CHECK-IN, AIR CARGO AND CUSTOMS INSPECTION.

With a 1,000 mm wide by 1,000 mm high tunnel opening, the Rapiscan 628XR meets the most stringent requirements of multiple global regulatory requirements including French civil aviation authority (STAC).

The Rapiscan 628XR has been approved and included on the U.S. TSA Air Cargo Screening Technology List (ACSTL) and the Transport Canada (TC) Air Cargo Security Program (ACS).

### DETECTION OF EXPLOSIVES AND NARCOTICS ALERT

Target™ and NARCScan™ are designed to assist operators in the detection of a range of explosives and narcotics respectively in real time during the scanning process by marking a potential threat on the X-ray image. Rapiscan detection algorithms are based on regulatory material analysis techniques.

### EASE OF USE PROVIDING HIGHEST THROUGHPUT

With over 13 image processing tools and detection alert algorithm functions, the feature rich software allows the operator to more easily and accurately search for contraband.

### REGULATORY COMPLIANCE

Rapiscan 628XR performance is in full compliance with the European Union regulations (EC) No. 300/2008, (EU) No. 2015/1998 and Commissions Decision C (2015)8005 for aviation security.



# RAPISCAN 628XR

**Rapiscan**<sup>®</sup>  
systems  
An OSI Systems Company

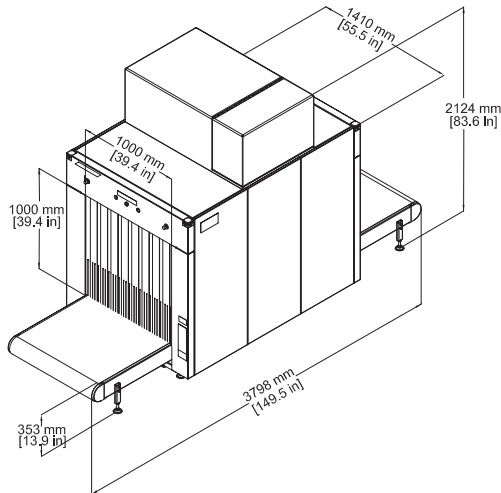

## PHYSICAL SPECIFICATIONS

|                      |   |
|----------------------|---|
| Dimensions:          | Length: 3,798 mm (149.5 in.)<br>Width: 1,410 mm (55.5 in.)<br>Height: 2,124 mm (83.6 in.) |
| Tunnel Size:         | 1,000 mm (W) x 1,000 mm (H)<br>(39.4 x 39.4 in.)  |
| Conveyor Speed:      | 0.20 m/sec (39.4 ft./min)   |
| Conveyor Load (Max): | 200 Kg (441 lbs) evenly distributed   |
| Conveyor Height:     | 353 mm (13.9 in.)   |
| Weight (Approx.):    | Net: 1,250 Kg (2,756 lbs)   |
| System Power:        | 115/230 VAC ±10%, 60/50Hz   |

## X-RAY GENERATOR AND IMAGE PERFORMANCE<sup>1</sup>

|                    |                                 |
|--------------------|---------------------------------|
| Steel Penetration: | 30 mm typical; 28 mm standard   |
| Wire Resolution:   | 40 AWG typical; 38 AWG standard |
| Generator Cooling: | Sealed oil bath with forced air |
| Anode Voltage:     | Operating at 160kV              |
| Tube Current:      | 1.0 mA                          |
| Orientation:       | Vertically Downward             |

## OPERATING ENVIRONMENT

|                        |                         |
|------------------------|-------------------------|
| Storage Temperature:   | -20°C to 50°C           |
| Operating Temperature: | 0°C to 40°C             |
| Relative Humidity:     | 5 to 95% non-condensing |

## PROTECTION CLASS

|                         |                   |
|-------------------------|-------------------|
| System:                 | IP20              |
| Operator Control Panel: | IP43 <sup>2</sup> |

## REGULATORY

- TSA Air Cargo Screening Technology List (ACSTL) Qualified
- Transport Canada (TC) Air Cargo Qualified
- Regulation (EC) No. 300/2008 Compliant
- Regulation (EU) No. 2015/1998 Compliant
- EU Commissions Decision (EU) C(2015)8005 Compliant
- French Civil Aviation Authority (STAC) Certified

## HEALTH & SAFETY

Rapiscan Systems' cabinet X-ray products comply with all applicable U.S. FDA and equivalent international regulatory agency requirements, contained in the cabinet X-ray radiation safety performance standard [21 CFR 1020.40] and the general performance standard [21 CFR Part 1010] as well as IEC standard 61010-2-091.

Rapiscan baggage and parcel inspection systems radiation emission leakages are well below the required regulatory limits with less than 1 µSv/hr at 10 cm from all surfaces of cabinet X-ray.

## OPTIONS AND ACCESSORIES

- Explosives Detection Alert (Target™)
- Narcotics Detection Alert (NARCScan™)
- Density Threshold Alert (DTA)
- Threat Image Projection (TIP)
- Threat Image Projection Network (TIPNet)
- Remote Image Archive Review (NETView™)
- Network X-ray management automation and link system (NEXLink™)
- Multi-System Network Display Station (NDS)
- Automatic Image Archiving
- Enhanced Image Archiving
- Operator Training Program (OTP)
- Manual Scan
- Operator Pedestal
- Foot Mat
- Optical Operator Presence Sensor
- SmartCard Login
- Power Conditioner
- Conveyor Accessories
- Remote Workstation
- Universal Printer Support

<sup>1</sup> Stated performance as measured by Rapiscan Imaging Validation Test Kit.

<sup>2</sup> With optional replaceable cover.

With continual development of our products Rapiscan Systems reserves the right to amend specifications without notice. Product pictures are for general reference. Please note that due to US laws and regulations, not all Rapiscan products are available for sale in all countries without restriction. Please contact your Rapiscan Systems sales representative for more information.

## AMERICAS, CARIBBEAN

2805 Columbia Street  
Torrance,  
California  
90503  
UNITED STATES of AMERICA

Tel: +1 310-978-1457  
Fax: +1 310-349-2491

## EUROPE, MIDDLE EAST, AFRICA

X-Ray House  
Bonehurst Road  
Salfords  
Surrey RH1 5GG  
UNITED KINGDOM

Tel: +44 (0) 870-7774301  
Fax: +44 (0) 870-7774302

## ASIA

240 Macpherson Road  
#07-01 Pines Industrial Building  
Singapore  
348574  
SINGAPORE

Tel: +65-6846-3511  
Fax: +65-6743-9915



Rapiscan Systems is ISO 9001:2008 and ISO 14001:2004 + Cor. 1:2009 Certified

[sales@rapiscansystems.com](mailto:sales@rapiscansystems.com)  
[www.rapiscansystems.com](http://www.rapiscansystems.com)